

# GEOMETRY OF MINKOWSKI–VORONOI TESSELLATIONS OF THE PLANE

OLEG KARPENKOV, ALEXEY USTINOV

ABSTRACT. In this paper we investigate the combinatorial structure of Minkowski–Voronoi continued fractions. Our main goal is to prove the asymptotic stability of Minkowski–Voronoi complexes in special two-parametric families of rank-1 lattices. In addition we construct explicitly the complexes for the case of White’s rank-1 lattices and provide with a hypothetic description in a more complicated settings.

## CONTENTS

Introduction	2
1. Basic notions and definitions	3
1.1. Minkowski–Voronoi complex	4
1.2. Minkowski–Voronoi tessellations of the plane	5
1.3. Canonical diagrams of three-dimensional Minkowski–Voronoi complexes for finite axial sets in general position	6
1.4. Minkowski–Voronoi complexes for lattices	10
2. Construction of canonical diagrams	11
3. Theorem on stabilization of Minkowski–Voronoi complex	15
3.1. Classification of relative minima of $\Gamma(a, b, N)$	17
3.2. Asymptotic comparison of coordinate functions	22
3.3. Conclusion of the proof of Theorem 3.1	25
4. A few words about lattices $L(a, b, N)$ with small $a$	25
4.1. Alphabetical description of canonical diagrams for lattices $\Gamma(a, b, N)$ with small $a$	25
4.2. The case of lattices $\Gamma(1, b, N)$	25
4.3. The case of lattices $\Gamma(2, b, N)$	27
References	28

---

*Date:* 25 June 2014.

*Key words and phrases.* Minkovski minima, Minkowski–Voronoi continued fraction, lattice geometry. Alexei Ustinov is supported by Dynasty Foundation and RFBR grant 14-01-90002.

## INTRODUCTION

In this paper we study one of the geometrical generalizations of continued fractions proposed independently by G.F. Voronoi [30, 31] and H. Minkowski [23, 24]. Minkowski-Voronoi continued fractions are used as one of the main tools for the calculations of the fundamental units of algebraic fields. Recently we have discovered that finite Minkowski-Voronoi continued fractions in special two-dimensional families of three-dimensional lattices are combinatorially stable. The main aim of current paper is to give a proof of this result.

The question of generalizing continued fractions to the multidimensional case was risen by the first time by C. Hermite [21] in 1839. Since than, many different generalizations were introduced (see [22] for a general reference). Although the approaches of G.F. Voronoi and H. Minkowski are rather different (see in [15, 16, 20, 25]), they deal with the same geometrical object, with the set of local minima for lattices (we provide with all necessary definitions in Section 1). One of the most important properties of the set of local minima is that it admits adjacency relation, which provides the graph structure on the set of local minima. This property is essential for the algorithmic applications of Minkowski-Voronoi continued fractions, see [3, 4, 5, 6, 12, 18, 33, 34].

Regular continued fractions are used as a tool in numerous problems related to two-dimensional lattices. Although Minkowski-Voronoi continued fractions are much more complicated combinatorially than classical continued fractions, there is a number of significant three-dimensional results related to them. For instance, in [12] T.W. Cusick proposed an efficient method (based on Minkowski's algorithm) for finding arbitrarily many integer solutions  $(x, y, z)$  of the Diophantine inequality

$$|x + \alpha y + \beta z| \max\{y^2, z^2\} < c$$

for extreme values of  $c$  (see [13]). Here  $\alpha$  defines a totally real cubic field  $F$  over the field of rational numbers, and the numbers 1,  $\alpha$ , and  $\beta$  form an integral basis for  $F$ . Using Minkowski-Voronoi continued fractions G. Ramharter proved Gruber's conjecture (i.e., Mordell's inverse problem) on volumes of extreme (admissible centrally symmetric with faces parallel to the coordinate axes) parallelepipeds, see [26]. The beginning of 3-dimensional analogue of Markov spectrum is known due to H. Davenport and H.P.F. Swinnerton-Dyer, see [14, 27] (see also isolation theorems in [10, 11]).

The connections between Minkowski-Voronoi continued fractions and Klein polyhedra are studied by V.A. Bykovskii and O.N. German, see [8, 19]. Further there is a three-dimensional analog of Vahlen's theorem, see [1, 7, 28, 29]. Basing on the analytical properties of local minima in multidimensional integer lattices V.A. Bykovskii in [9] proved essentially new bounds for discrepancy of Korobov nets, which are conjectured to be sharp.

Now let us mention two high-priority open problems in the studies of Minkowski-Voronoi continued fractions.

**Problem 1.** Give a combinatorial classification of finite and periodic Minkowski-Voronoi continued fractions.

**Problem 2.** Construct infinite families of finite three-dimensional Minkowski-Voronoi continued fractions with bounded or growing at a slow rate “partial quotients”. (Partial quotients here are the coefficients of the transition matrices between the adjacent relative minima. Such continued fractions correspond to Korobov nets with small deviations.)

Although the first publications on Minkowski-Voronoi continued fractions were made more than a hundred years ago, there is nothing known regarding these problems. In this paper we are making the first step in the systematic study of Minkowski-Voronoi continued fractions, our main contributions to the above problems are as follows.

- First, we introduce a general natural construction of the Minkowski-Voronoi complex, which is natural in all the dimensions. In particular, we give an alphabetic description of the canonical diagrams for White’s lattices in dimension three, and conjecture other alphabetic descriptions for a broader families of lattices.
- Second, we construct a countable number of two-parametric families of finite lattices whose three-dimensional continued fractions are asymptotically stable. We have discovered this surprising phenomenon via numerous experiments. The formulation and the proof are given in Theorem 3.1 below.

**This paper is organized as follows.** We start in Section 1 with general notion and definitions. We define minimal sets in the sense of Voronoi and show how to introduce the structure of the Minkowski–Voronoi complex on the sets of all Voronoi minimal sets. Further we describe two important representations of this complex in three dimensional case: Minkowski–Voronoi tessellations and canonical diagrams. Finally we briefly discuss how to adapt all the definition to the case of lattices.

Further in Section 2 we describe the techniques to construct canonical diagrams of Minkowski–Voronoi complexes for finite axial sets in general position. We show the algorithm that produces a canonical diagram for every finite axial set, which provides the existence of canonical diagrams. The algorithm of this section was extensively used for the calculation of many examples leading to the results of the next two sections.

Section 3 contains the main result this article. We formulate and prove the stabilization theorem of Minkowski–Voronoi complexes for special two-parametric families in the set of all rank-1 lattices.

Finally in Section 4 we introduce the alphabetical description of canonical diagrams for lattices. This is a simple way to describe canonical diagram that arisen in the study of various examples. We conjecture that in the case of the simplest families of lattices (like in the case of lattices corresponding to empty simplices described by White’s theorem, see in [32]) it is possible to describe any canonical diagram with finitely many distinct letters. In this section we provide several open problems and conjectures regarding the alphabetic description.

## 1. BASIC NOTIONS AND DEFINITIONS

We start this section with general definitions of minimal subsets in the sense of Voronoi for a given set. Further we define Minkowski–Voronoi complex associated with the set of all

minimal subsets. In particular in three-dimensional case we describe a Minkowski-Voronoi tessellation of the plane encoding the geometric nature of the complex. In conclusion of this section we say a few about the case of lattices.

In this paper we work with finite axial subsets of  $\mathbb{R}_{\geq 0}^n$  in general position.

**Definition 1.1.** A subset  $S \subset \mathbb{R}_{\geq 0}^n$  is said to be *axial* if  $S$  contains points on each of the coordinate axes.

**Definition 1.2.** We say that a axial subset  $S \subset \mathbb{R}_{\geq 0}^3$  is *in general position* if the following conditions hold:

*i*). Each coordinate plane contains exactly two points of  $S$  none of which are at the origin; these points are on different coordinate axes.

*ii*). Each other plane parallel to a coordinate plane contains at most one point of  $S$ .

**1.1. Minkowski–Voronoi complex.** Let  $A$  be an arbitrary finite subset of  $\mathbb{R}_{\geq 0}^n = (\mathbb{R}_{\geq 0})^n$ . For  $i = 1, \dots, n$  we set

$$\max(A, i) = \max\{x_i \mid (x_1, \dots, x_n) \in A\}$$

and define the parallelepiped  $\Pi(A)$  as follows

$$\Pi(A) = \{(x_1, \dots, x_n) \mid 0 \leq x_i \leq \max(A, i), i = 1, \dots, n\}.$$

**Definition 1.3.** Let  $S$  be an arbitrary finite axial subset of  $\mathbb{R}_{\geq 0}^n$  in general position. An element  $\gamma \in S$  is called a *Voronoi relative minimum* with respect to  $S$  if the parallelepiped  $\Pi(\{\gamma\})$  contains no points of  $S \setminus \{\gamma\}$ . The set of all Voronoi relative minima of  $S$  we denote by  $\text{Vrm}(S)$ .

**Definition 1.4.** Let  $S$  be an arbitrary finite axial subset of  $\mathbb{R}_{\geq 0}^n$  in general position. A finite subset  $F \subset \text{Vrm}(S)$  is called *minimal* if the parallelepiped  $\Pi(F)$  contains no points of  $\text{Vrm}(S) \setminus F$ . We denote the set of all minimal  $k$ -element subsets of  $\text{Vrm}(S) \subset S$  by  $\mathfrak{M}_k(S)$ .

It is clear that any minimal subset of a minimal subset is also minimal.

**Definition 1.5.** Consider a finite subset  $S$  in general position. A *Minkowski–Voronoi complex*  $MV(S)$  is an  $(n - 1)$ -dimensional complex such that

*(i)* the  $k$ -dimensional faces of  $MV(S)$  are enumerated by its minimal  $(n - k)$ -element subsets (i.e., by the elements of  $\mathfrak{M}_{n-k}(S)$ );

*(ii)* a face with a minimal subset  $F_1$  is adjacent to a face with a minimal subset  $F_2 \neq F_1$  if and only if  $F_1 \subset F_2$ .

*Remark 1.6.* In the three-dimensional case it is also common to consider the Voronoi and Minkowski graphs that are subcomplexes of the Minkowski–Voronoi complex. They are defined as follows.

The *Voronoi graph* is the graph whose vertices and edges are respectively vertices and edges of the Minkowski–Voronoi complex.

The *Minkowski graph* is the graph whose vertices are edges and edges are faces of the Minkowski–Voronoi complex (two vertices in the Minkowski graph are connected

by an edge if and only if the corresponding faces in the Minkowski–Voronoi complex have a common edge.

**Example 1.7.** Let us consider an example of a 6-element set  $S_0 \subset \mathbb{R}_{\geq 0}^3$  defined as follows

$$S_0 = \{\gamma_1, \gamma_2, \gamma_3, \gamma_4, \gamma_5, \gamma_6\},$$

where

$$\begin{aligned} \gamma_1 &= (3, 0, 0), & \gamma_2 &= (0, 3, 0), & \gamma_3 &= (0, 0, 3), \\ \gamma_4 &= (2, 1, 2), & \gamma_5 &= (1, 2, 1), & \gamma_6 &= (2, 3, 4). \end{aligned}$$

There are only five Voronoi relative minima for the set  $S_0$ , namely the vectors  $\gamma_1, \dots, \gamma_5$ . The Minkowski–Voronoi complex contains 5 vertices, 6 edges, and 5 faces. Its vertices are

$$\begin{aligned} v_1 &= \{\gamma_1, \gamma_3, \gamma_4\}, & v_2 &= \{\gamma_3, \gamma_4, \gamma_5\}, & v_3 &= \{\gamma_1, \gamma_4, \gamma_5\}, \\ v_4 &= \{\gamma_2, \gamma_3, \gamma_5\}, & v_5 &= \{\gamma_1, \gamma_2, \gamma_5\}. \end{aligned}$$

Its edges are

$$\begin{aligned} e_1 &= \{\gamma_1, \gamma_3\}, & e_2 &= \{\gamma_3, \gamma_2\}, & e_3 &= \{\gamma_1, \gamma_2\}, \\ e_4 &= \{\gamma_3, \gamma_4\}, & e_5 &= \{\gamma_1, \gamma_4\}, & e_6 &= \{\gamma_4, \gamma_5\}, \\ e_7 &= \{\gamma_3, \gamma_5\}, & e_8 &= \{\gamma_1, \gamma_5\}, & e_9 &= \{\gamma_2, \gamma_5\}. \end{aligned}$$

Its faces are

$$f_1 = \{\gamma_1\}, \quad f_2 = \{\gamma_2\}, \quad f_3 = \{\gamma_3\}, \quad f_4 = \{\gamma_4\}, \quad f_5 = \{\gamma_5\}.$$

Finally, we represent the complex  $MV(S)$  as a tessellation of an open two-dimensional disk. We show vertices (on the left), edges (in the middle), and faces (on the right) separately:

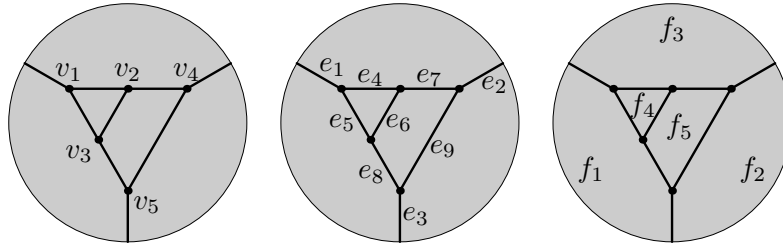

**1.2. Minkowski–Voronoi tessellations of the plane.** In this subsection we discuss a natural geometric construction standing behind the Minkowski–Voronoi complex in the three-dimensional case.

**Definition 1.8.** Let  $S$  be an arbitrary finite axial subset of  $\mathbb{R}_{\geq 0}^3$  in general position. The *Minkowski polyhedron* for  $S$  is the boundary of the set

$$S \oplus \mathbb{R}_{\geq 0}^3 = \{s + r \mid s \in S, r \in \mathbb{R}_{\geq 0}^3\}.$$

In other words, the Minkowski polyhedron is the boundary of the union of copies of the positive octant shifted by vertices of the set  $S$ .

**Proposition 1.9.** *The union of the compact faces of the Minkowski polyhedron is contained in*

$$\partial\left(\bigcup_{A \in \mathfrak{M}_3(S)} \Pi(A)\right).$$

□

**Definition 1.10.** The *Minkowski–Voronoi tessellation* for a finite axial set  $S \subset \mathbb{R}_{\geq 0}^3$  in general position is a tessellation of the plane  $x + y + z = 0$  obtained by the following three steps.

*Step 1.* Consider the Minkowski polyhedron for the set  $S$  and project it orthogonally to the plane  $x + y + z = 0$ . This projection induces a tessellation of the plane by edges of the Minkowski polyhedron.

*Step 2.* Remove from the tessellation of Step 1 all vertices corresponding to the local minima of the function  $x + y + z$  on the Minkowski polyhedron (these are exactly the images of the relative minima of  $S$  under the projection). Remove also all edges which are adjacent to the removed vertices.

*Step 3.* After Step 2 some of the vertices are of valence 1. For each vertex  $v$  of valence 1 and the only remaining edge  $wv$  with endpoint at  $v$  we replace the edge  $wv$  by the ray  $wv$  with vertex at  $w$  and passing through  $v$ .

**Proposition 1.11.** *The Minkowski–Voronoi tessellation for a finite axial set  $S$  in general position has the combinatorial structure of the Minkowski–Voronoi complex  $MV(S)$ .* □

**Example 1.12.** Consider the set  $S_0$  as in Example 1.7. In Figure 1 we show the Minkowski polyhedron (on the left) and the corresponding Minkowski–Voronoi tessellation (on the right). The local minima of the function  $x + y + z$  on the Minkowski polyhedron for  $S_0$  are the relative minima  $f_1, \dots, f_5$ . They identify the faces of the complex  $MV(S_0)$ . The local maxima of the function  $x + y + z$  on the Minkowski polyhedron for  $S_0$  are  $v_1, \dots, v_5$ , corresponding to the vertices of the complex  $MV(S_0)$ . The vertices  $v_1, \dots, v_5$  are as follows:

$$\begin{aligned} v_1 &= (3, 1, 3), & v_2 &= (2, 2, 3), & v_3 &= (3, 2, 2), \\ v_4 &= (1, 3, 3), & v_5 &= (3, 3, 1). \end{aligned}$$

**1.3. Canonical diagrams of three-dimensional Minkowski–Voronoi complexes for finite axial sets in general position.** Let us first describe a canonical labeling of edges and vertices of the Minkowski–Voronoi complex.

**1.3.1. Labels for edges and vertices.** Consider a minimal 3-element subset  $\{\gamma_1, \gamma_2, \gamma_3\}$ , it is a vertex of the Minkowski–Voronoi complex. There are exactly three edges that are adjacent to this vertex. They are enumerated by minimal 2-element subsets  $\{\gamma_1, \gamma_2\}$ ,  $\{\gamma_1, \gamma_3\}$ , and  $\{\gamma_2, \gamma_3\}$ . Hence there are exactly three vertices (this may include a vertex at infinity) that are connected with  $\{\gamma_1, \gamma_2, \gamma_3\}$  by an edge. In each of these vertices the corresponding minimal 3-element subset has exactly two elements in  $\{\gamma_1, \gamma_2, \gamma_3\}$ . Without loss of generality we consider one of them which is  $\{\gamma_1, \gamma_2, \gamma'_3\}$ . Notice that

$$\Pi(\{\gamma_1, \gamma_2, \gamma_3\}) \cap \Pi(\{\gamma_1, \gamma_2, \gamma'_3\}) = \Pi(\{\gamma_1, \gamma_2\}).$$

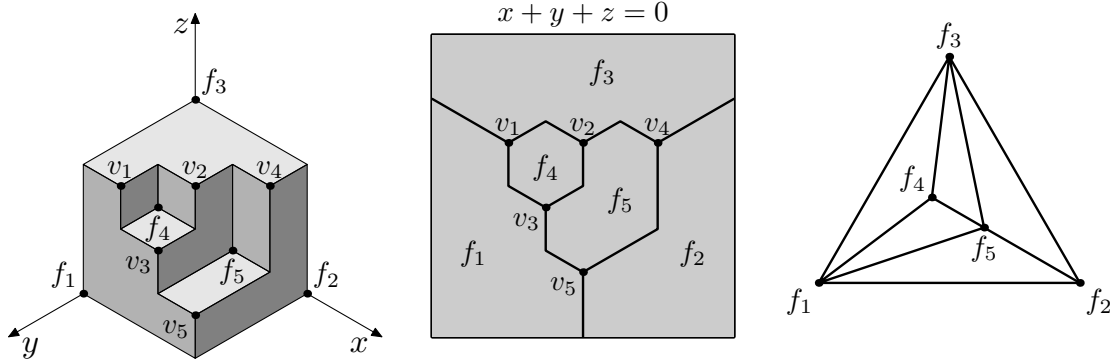

FIGURE 1. The Minkowski polyhedron (on the left), the corresponding Minkowski–Voronoi tessellation (in the middle), and the Minkowski graph (on the right).

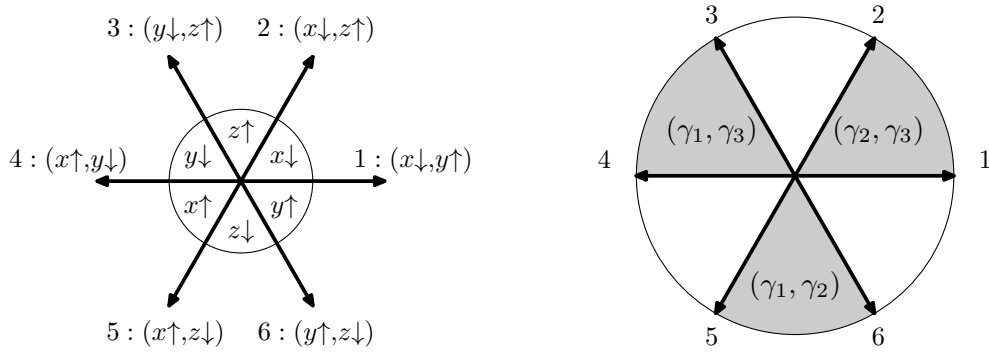

FIGURE 2. Six different directions corresponding to different colors.

Hence the parallelepipeds  $\Pi(\{\gamma_1, \gamma_2, \gamma'_3\})$  is obtained from  $\Pi(\{\gamma_1, \gamma_2, \gamma_3\})$  by increasing one of its sizes and by decreasing some other. This gives a natural coloring of each edge pointing out of the vertex  $(\{\gamma_1, \gamma_2, \gamma_3\})$  into six colors (each color indicate which coordinate we increase, which we decrease, and which stays unchanged).

**Definition 1.13.** To each color we associate one of the directions  $\frac{k\pi}{3}$  (where  $k = 0, 1, \dots, 5$ ) according to the scheme shown on Figure 2 from the left. We call such direction of an edge the *labeling* of this edge.

The *labeling* of a vertex is a collection of all labelings for all finite edges adjacent to this vertex.

1.3.2. *Geometric structure of vertex-stars.* Without loss of generality we suppose that  $\gamma_1$  has the greatest  $x$ -coordinate among the  $x$ -coordinates of  $\gamma_1, \gamma_2$ , and  $\gamma_3$ ; let  $\gamma_2$  have the greatest  $y$ -coordinate, and let  $\gamma_3$  have the greatest  $z$ -coordinate. There is only one edge adjacent to  $\{\gamma_1, \gamma_2, \gamma_3\}$  along which the first coordinate is decreasing, it is  $\{\gamma_2, \gamma_3\}$ . Therefore, each vertex that is not adjacent to infinite edges has exactly one edge in

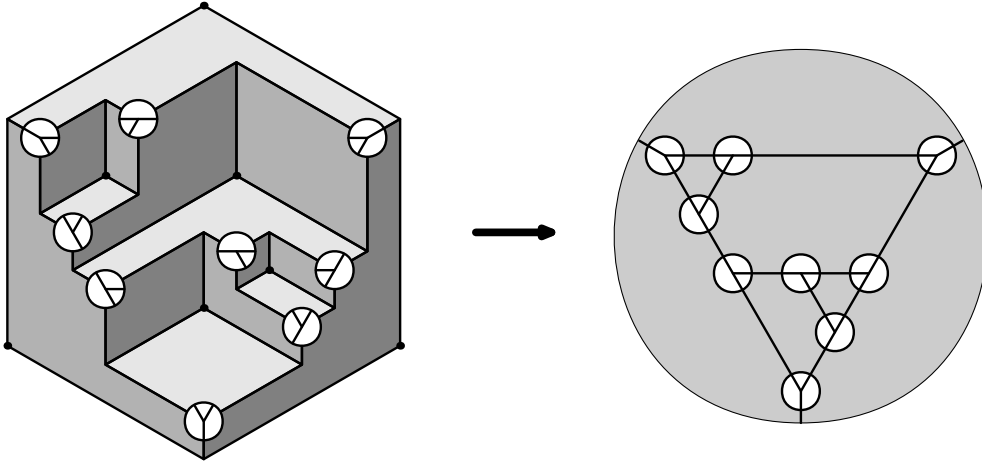
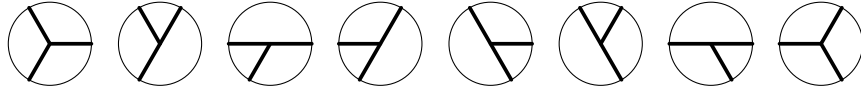

FIGURE 3. A Minkowski–Voronoi complex and its canonical diagram.

direction 1 or 2 (see Figure 2 from the right). Similarly, each vertex has exactly only edge in directions 3 or 4, and one edge in directions 5 or 6. Hence the following statement is true.

**Proposition 1.14.** *Each vertex of the Minkowski-voronoi complex that is not adjacent to infinite edges has one of the following eight labels*



□

1.3.3. *Definition of canonical diagrams.* Labeling of vertices and edges gives rise to the following geometric definition.

**Definition 1.15.** Consider a finite axial set  $S \subset \mathbb{R}_{\geq 0}^3$  in general position. We say that an embedding of the 1-skeleton of the Minkowski-Voronoi complex  $MV(S)$  to the plane with linear edges (some of them are infinite rays corresponding to infinite edges) is a *canonical diagram* of  $S$  if the following conditions holds:

- All finite edges are straight segments in the directions of its labels (i.e,  $\frac{k\pi}{3}$  for some  $k \in \mathbb{Z}$ ).
- Each vertex that does not contain infinite edges is a vertex of one of 8 types described in Proposition 1.14.

**Example 1.16.** Consider the Minkowski–Voronoi complex shown on Figure 3 from the left (for some set  $S$  which we do not specify here). Each vertex of the complex in the picture is represented by an appropriate label. Notice that we have exactly three vertices adjacent to infinite edges. On Figure 3 from the right we show the canonical diagram of this Minkowski–Voronoi complex.



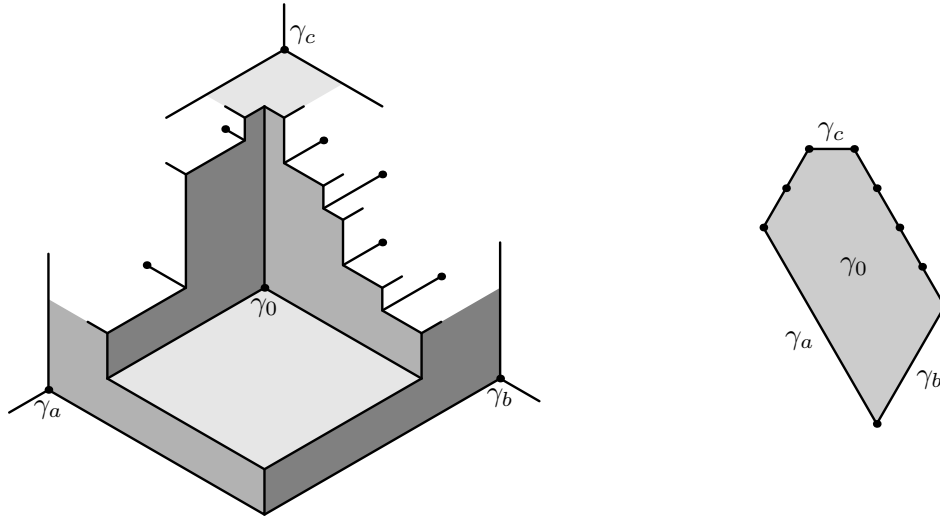

FIGURE 4. The union of three faces of Minkowski polyhedron representing  $\{\gamma_0\}$  (left); the canonical diagram for  $\{\gamma_0\}$  (right)

In Section 2 (Theorem 2.1) below we prove the existence of canonical diagrams for the case of finite axial subsets of  $\mathbb{R}_{\geq 0}^3$  in general position and give an algorithm to construct them.

1.3.4. *Geometry of faces in canonical diagrams.* Consider the Minkowski polyhedron for a finite axial subset  $S \subset \mathbb{R}_{\geq 0}^3$  in general position. Let  $\gamma_0$  be any of the local minima of  $S$  not contained in the coordinate planes. Then there are exactly three faces of the Minkowski polyhedron that meets at this minimum: each of such faces is parallel to one of the coordinate planes (see Figure 4 from the left). The boundary of their union consists of three "staircases" in the corresponding planes. Each staircase may have an arbitrary nonnegative number of stairs. On Figure 4 from the left such staircases have 0, 2, and 4 stairs respectively. By Minkowski convex body theorem, each staircase has only finitely many stairs.

So there is a natural cyclic order for all the relative minima that are neighbors of  $\gamma_0$ . There are three minima that present for any local minimum  $\gamma_0$ . These are the minima that we capture if we start to increase one of the dimensions of  $\Pi(\gamma_0)$ , namely  $x$ -, or  $y$ -, or  $z$ -dimension. We denote such minima by  $\gamma_a$ ,  $\gamma_b$ , and  $\gamma_c$  respectively (here we do not consider the boundary case when one of such minima does not exist). All the other neighboring minima are obtained by increasing simultaneously some two dimensional of the parallelepiped  $\Pi(\gamma_0)$ .

**Theorem 1.17.** *Each finite face in a canonical diagram has a combinatorial type*

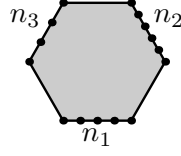

for some nonnegative integers  $n_1, n_2, n_3$  (where  $n_1, n_2,$  and  $n_3$  are the number of segments on the corresponding edges).  $\square$

Notice that if all  $n_0, n_1,$  and  $n_2$  are zeroes, we have the simplest possible type of face – the  $\nabla$ -shaped triangle.

**1.4. Minkowski–Voronoi complexes for lattices.** Further we will be about canonical diagrams for the sets associated with lattices. We discuss this briefly in current subsection.

1.4.1. *General construction.* Consider a lattice  $\Gamma \in \mathbb{R}^n$  defined as follows:

$$\Gamma = \left\{ \sum_{i=1}^n m_i g_i \mid m_i \in \mathbb{Z}, i = 1, \dots, n \right\},$$

where  $g_1, \dots, g_n$  are linearly independent vectors in  $\mathbb{R}^n$ . Define

$$|\Gamma| = \{(|x_1|, \dots, |x_n|) \mid (x_1, \dots, x_n) \in \Gamma\} \setminus \{(0, \dots, 0)\}.$$

**Definition 1.18.** Consider an arbitrary full rank lattice  $\Gamma$  in  $\mathbb{R}^n$ . The complex  $MV(|\Gamma|)$  is called the *Minkowski–Voronoi complex* for  $\Gamma$ , we denote it by  $MV(\Gamma)$ .

1.4.2. *1-rank integer lattices in  $\mathbb{R}^3$ .* From now on we consider special three-dimensional lattices with integer vectors (i.e., vectors, whose all coordinates are integers).

**Definition 1.19.** Let  $a, b,$  and  $N$  be arbitrary positive integers. The lattice

$$\{(m_1(1, a, b) + m_2(0, N, 0) + m_3(0, 0, N) \mid m_1, m_2, m_3 \in \mathbb{Z}\}$$

is said to be the *1-rank lattice*. We denote it by  $\Gamma(a, b, N)$ .

All local minima (except the ones on the coordinate axes) are contained in the cube  $[-N/2, N/2]$ , and, therefore, they form a finite set. In fact, a stronger statement hold.

**Proposition 1.20.** *Let  $a, b,$  and  $N$  be arbitrary positive integers such that both  $a$  and  $b$  are relatively prime with  $N$ . Then the set  $\text{Vrm}(|\Gamma(a, b, N)|)$  is a finite axial set in general position.*  $\square$

One of the consequences of this proposition is that we can apply the algorithm of the next section to produce canonical diagrams for the sets  $\text{Vrm}(|\Gamma(a, b, N)|)$ . Basing on this examples we have detected stabilization of Minkowski–Voronoi complex discussed later in Section 3.

2. CONSTRUCTION OF CANONICAL DIAGRAMS

In this section we describe the algorithm to construct canonical diagrams of Minkowski–Voronoi complexes for finite axial sets in general position. We do not have an intention to optimize the location of points in the diagram, so some faces in them may become quite narrow. In order to improve the visualization of the diagram itself one should apply “Schnyder wood” techniques, see [17]. The algorithm of this section always returns a canonical diagram, which provides the existence of canonical diagrams. We formulate this statement as follows.

**Theorem 2.1.** *Let  $S$  be a finite axial subset of  $\mathbb{R}_{\geq 0}^3$  in general position. Then  $MV(S)$  admits a canonical diagram.*

*Proof.* One of the canonical diagram is explicitly defined by the algorithm described below. □

Let us first introduce some necessary notions and definitions.

We assume that the set  $S$  is a axial set in general position. In particular this means that  $S$  contains three points  $(N_1, 0, 0)$ ,  $(0, N_2, 0)$ , and  $(0, 0, N_3)$  for some  $N_1, N_2, N_3 > 0$ . Notice that for every two of these three points there is exactly one minimal triple of  $S$  containing them. These triples correspond to three vertices of  $MV(S)$  which we denote by  $v_L$ ,  $v_R$ , and  $v_B$  (right, left, and bottom vertices) where:

$$\begin{aligned} \{(0, N_2, 0), (0, 0, N_3)\} &\subset v_R, \\ \{(N_1, 0, 0), (0, 0, N_3)\} &\subset v_L, \\ \{(N_1, 0, 0), (0, N_2, 0)\} &\subset v_B. \end{aligned}$$

Set

$$e_1 = \left(-\frac{1}{2}, \frac{\sqrt{3}}{2}\right); \quad e_2 = \left(\frac{1}{2}, \frac{\sqrt{3}}{2}\right); \quad e_3 = (1, 0).$$

Recall that all the edges in canonical diagrams have directions  $\pm e_1$ ,  $\pm e_2$ , or  $\pm e_3$ .

By a *directed path* in the 1-skeleton of the Minkowski–Voronoi complex we consider the sequence of vertices of  $MV(S)$  such that each two consequent vertices are connected by an edge of  $MV(S)$ .

**Definition 2.2.** We say that a directed path  $p_0 p_1 \dots p_n$  in the 1-skeleton of the Minkowski–Voronoi complex  $MV(S)$  is *ascending* if the following conditions are fulfilled

- (i)  $p_0 = v_B$ ;
- (ii)  $p_n = v_L$ ;
- (iii) for every  $i = 0, \dots, n - 1$  the edge  $p_i p_{i+1}$  is of one of the following three directions:  $e_1$ ,  $e_2$ , or  $-e_3$ .

**Definition 2.3.** Let us consider the union of all compact faces of  $MV(S)$  and an ascending path  $P$ . The path  $P$  divides the union of all compact faces into several connected components. We say that a compact face, an edge not contained in  $P$ , or a vertex not contained in  $P$  is *to the right* (or *to the left*) of the path  $P$  if it is (or, respectively, it is not) in the same connected component with the point  $v_R$ . In the exceptional case when

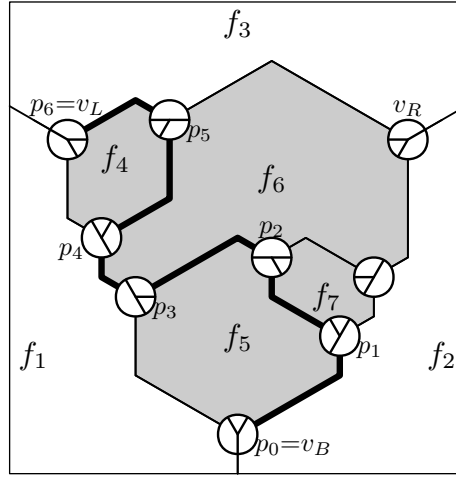

FIGURE 5. A Minkowski–Voronoi complex and its canonical diagram.

$v_R$  is a vertex of  $P$  we say that all compact faces, edges (not in  $P$ ), and vertices (not in  $P$ ) are to the left of  $P$ .

**Example 2.4.** On Figure 5 we consider an example of Minkowski–Voronoi tessellation. It contains three noncompact faces  $f_1, f_2, f_3$  and four compact faces  $f_4, f_5, f_6, f_7$  (all compact faces are in gray color). The path  $P = p_0p_1p_2p_3p_4p_5p_6$  is ascending. It divides the union of all compact parts into three connected components. The faces  $f_6$  and  $f_7$  are to the right of  $P$ , while the faces  $f_4$  and  $f_5$  are to the left of  $P$ .

Let us bring together the main properties of ascending paths.

**Proposition 2.5.** *Let  $P = p_0p_1 \dots p_n$  be an ascending path.*

(i) *Let  $\Pi(p_0), \dots, \Pi(p_n)$  be the sequence of parallelepipeds defined by the triples of points corresponding to  $p_i$  ( $i = 0, \dots, n$ ). Then, first, the sequence of  $y$ -sizes (i.e., maximal  $y$ -coordinates) of such parallelepipeds is non-increasing. Second, the sequence of  $z$ -sizes of the parallelepipeds is non-decreasing.*

(ii) *There exists only one ascending path that contains the vertex  $v_R$ .*

(iii) *If the path does not contain  $v_R$ , then there exists a vertex  $w$  outside the path and an integer  $i$  such that the edge  $p_iw$  is an edge of Minkowski–Voronoi complex in direction  $e_2$ .*

(iv) *All edges starting at some  $p_i$  to the right of  $P$  are either in direction  $e_2$  or in direction  $e_3$ .*

*Proof.* (i). The first item follows directly from the definition of labeling (Definition 1.13).

(ii). First of all, let us construct the following directed path in the 1-skeleton of  $MV(S)$ . This path consists of two parts. In the first part of the path we collect all vertices (without repetitions) that include the point  $(0, N_2, 0)$ ; all such vertices are consequently joined by

the edge in direction  $e_2$  starting with  $v_B$  ending with  $v_R$ . The second part of the path consists of vertices (passed once) that include the point  $(0, 0, N_3)$ ; all such vertices are consequently joined by the edge in direction  $-e_3$  starting with  $v_R$  ending with  $v_L$ . By construction this path is ascending.

Suppose now we have some other ascending path through  $v_R$ . Let us first consider the part of the path between  $v_B$  and  $v_R$ . The  $y$ -sizes of  $\Pi(v_B)$  and  $\Pi(v_R)$  are equal to  $N_2$ , and hence by Proposition 2.5(i) all the  $y$ -sizes of all the parallelepipeds within the path between  $v_B$  and  $v_R$  are equal to  $N_2$ . For the edges with directions  $e_1$  and  $-e_3$   $y$ -size of the parallelepiped strictly increase, and hence there are none of them in the part of the path between  $v_B$  and  $v_R$ . Hence all the edges are in direction  $e_2$ , and, therefore, this part of the path coincides with the first part of the ascending path constructed before.

The second part of the path is between  $v_R$  and  $v_L$ . Here the  $z$ -sizes of all the corresponding parallelepipeds are equal to  $N_3$  (since by Proposition 2.5(i) the sequence of  $z$ -sizes is non-decreasing and since all  $z$ -sizes are bounded by  $N_3$  from above). Therefore, this part of the path does not contain the directions  $e_1$  and  $e_2$  that increase  $z$ -sizes. Hence all the directions are  $-e_3$ , and this part of the path coincides with the second part of the considered before path.

Therefore, there exists and unique ascending path through  $v_R$ .

(iii). Consider an ascending path that do not contain  $v_R$ . Let us find the last vertex that contains  $(0, N_2, 0)$ . Since it is not  $v_R$ , there is an edge in direction  $e_2$  at this point. This edge do not change  $y$ -size of the parallelepiped and hence it is not in the ascending path.

(iv). The properties of being from the right or from the left are detected from the Minkowski-Voronoi tessellation for the corresponding set. Hence it is enough to prove the statement locally, considering only eight possible labels of the vertices shown in the figure of Proposition 1.14. It is clear that all possible ascending paths trough all such vertices either do not contain edges directed to the right, or the directions are either  $e_2$  or  $e_3$ .  $\square$

Now we outline the main steps of the algorithm.

**Algorithm to construct a canonical diagram of the Minkowski–Voronoi complex**

**Input data.** We are given by a finite strict subset  $S$  of  $\mathbb{R}_{\geq 0}^3$  in general position containing three points  $(N_1, 0, 0)$ ,  $(0, N_2, 0)$ , and  $(0, 0, N_3)$ .

**Goal of the algorithm.** Draw the canonical diagram for the set  $S$ .

**Preliminary Step i.** First of all we construct the Minkowski-Voronoi complex  $MV(S)$ . This is done by comparing coordinates of the points of the set  $S$ . In the output of this step we have:

- the list of all Voronoi relative minima  $v_1, \dots, v_{n(v)}$ ;
- the list of all edges  $e_1, \dots, e_{n(e)}$  of  $MV(S)$ ;
- the list of all faces  $f_1, \dots, f_{n(f)}$  of  $MV(S)$ ;

- the adjacency table for the complex  $MV(S)$ ;
- all vertices and edges of the Minkowski polyhedron.

**Preliminary Step ii.** After the previous step is completed we have all the data to construct the Minkowski–Voronoi tessellation. In order to do this we apply the algorithm of Definition 1.10 to the Minkowski polyhedron. In the output of this step we have:

- the directions of all the edges;
- for every ascending path  $P$  and for every face  $f_i$  we know whether  $f_i$  is to the left of the path  $P$  or not.

**Step 1.** We start with the bottom vertex  $v_P = p_0$ . We assign to  $p_0$  the coordinates:  $(0, 0)$ . Further, we construct the ascending path of vertices  $p_0, p_1, \dots, p_n$  of all vertices whose triples include the point  $(N_1, 0, 0)$  of the set  $S$ . The corresponding coordinates are assigned as follows

$$p_i = \frac{i}{n}e_1.$$

Denote by  $F$  the set of compact faces for which we have already constructed the coordinates. At this Step  $F$  is empty. In addition we choose the path  $P = p_0 \dots p_n$ . It is clear that the path  $P$  is ascending.

**Recursion Step.** At each step we start with the set  $F$  of all constructed faces and an ascending path  $P = p_0 \dots p_n$ , which separates the union of the constructed faces and all the other faces. All faces of  $F$  are the faces to the left of  $P$  (like faces  $f_5$  and  $f_6$  on Figure 5).

If  $P$  contains the vertex  $v_R$ , then the algorithm terminates, by Proposition 2.5(ii) we have constructed a canonical diagram for  $MV(S)$ .

Suppose now that  $P$  does not contain  $v_R$ . Then by Proposition 2.5(iii) there exists an edge in direction  $e_2$  with endpoint at some  $p_i$ . Let  $p_k$  be such vertex with the largest possible  $k$ , and denote by  $w_1$  the other endpoint of the edge starting at  $p_k$  with direction  $e_2$ . Denote by  $f$  the face adjacent to  $p_k w_1$  from the left side. We have not yet constructed the face  $f$  since it is to the right of  $P$ . Suppose that  $p_k, \dots, p_{k+j}$  are vertices of  $f$  and  $p_{k+j+1}$  is not a vertex of  $f$ .

By Proposition 1.14 there exists an edge leaving the vertex  $p_k$  either in direction  $e_1$  or in direction  $-e_3$ . In both cases this edge is adjacent to the same face as the edge  $p_k w_1$ , and in both cases this is the only choice for the edge  $p_k p_{k+1}$ . Therefore,  $j \geq 1$ , or in other words the edge  $p_k p_{k+1}$  is the edge of  $f$ .

We enumerate the vertices of  $f$  clockwise as follows

$$p_k, \dots, p_{k+j}, w_m, \dots, w_1$$

The edge  $p_{k+j} w_m$  is to the right of  $P$ , hence by Proposition 2.5(iv) it is either in direction  $e_2$  or in direction  $e_3$ . By the assumption the vertices  $p_{k+1}, \dots, p_n$  do not have adjacent edges in direction  $e_2$ . Hence the direction of  $p_{k+j} w_m$  is  $e_3$ . Now Theorem 1.17 (on general structure of faces) implies that all vertices  $w_1, \dots, w_m$  are in a line with direction  $e_1$ . Since  $f$  is to the right of  $P$ , all vertices  $w_1, \dots, w_m$  are to the right of  $P$  as well.

Let us assign the coordinates to the vertices  $w_1, \dots, w_m$ . Let  $u$  be the intersection point of the line containing  $p_k$  and parallel to  $e_2$  and the line containing  $p_{k+j}$  and parallel to  $e_3$ . In case when  $m = 1$  we assign  $w_1 = u$ . Suppose  $m > 1$ . Consider two subsegments of  $uv_k$   $uv_l$  with endpoints  $u$  respectively and with length

$$\frac{\min(|uv_k|, |uv_l|)}{2}.$$

denote the other two endpoints of such segments by  $u_k$  and  $u_l$  respectively. Subdivide  $u_k u_l$  into  $m - 1$  segments of the same length, and assign to  $w_1, \dots, w_m$  the corresponding consequent endpoints of the subdivision. This gives the expressions for the assigned coordinates of all new points  $w_1, \dots, w_m$ .

The recursion step is completed. We goto the next recursion step with a new data  $F' = F \cup \{f\}$  and

$$P' = (p_0, \dots, p_k, w_1, \dots, w_m, p_{k+j}, \dots, p_n).$$

First, the difference between  $P$  and  $P'$  is that the face  $f$  is to the right of  $P$  and to the left of  $P'$ . Hence  $F'$  is the set of all faces that are to the left of  $P'$  (it is the set of all constructed faces). Second, since all the added edges in the path follow directions  $e_2$ ,  $e_1$ , and  $-e_3$ , the path  $P'$  is ascending. Hence we are in correct settings for the next step.

*Remark 2.6.* The number of recursion steps coincides with the number of relative minima, which is the number of faces in our diagram. Hence the algorithm stops in a finite time.

### 3. THEOREM ON STABILIZATION OF MINKOWSKI–VORONOI COMPLEX

In numerous examples that we have calculated we observed an interesting regularity: it turns out that the set of all rank-1 lattices contains infinitely many remarkable two-parametric families. The Minkowski-Voronoi complexes in such families stabilize in a sense that for the choice of relatively large parameters of the families the corresponding complexes coincide. It is somehow similar to consider rank-1 lattices in one-dimensional case whose continued fractions are of the same length, the corresponding one-dimensional Minkowski-Voronoi complexes of such lattices simply coincide. In two-dimensional case the situation is more complicated it is described by the next theorem.

**Theorem 3.1. (Minkowski–Voronoi complex stabilization.)** *Let  $a$  be any positive integer. Consider relatively prime positive integers  $\alpha$  and  $\beta$  such that  $0 < \beta < \alpha a$ , and let an integer  $\gamma$  satisfy  $0 \leq \gamma < a$ . Put*

$$\begin{aligned} b(t) &= \alpha a t + \beta; \\ N(t, u) &= b(t)(a u + \gamma) + \alpha = (\alpha a t + \beta)(a u + \gamma) + \alpha, \end{aligned}$$

where  $t$  and  $u$  are positive integer parameters. Suppose that the numbers  $a$  and  $N$  are relatively prime. Then the following three statements hold.

**( $t, u$ )-stabilization:** *there exist  $t_0$  and  $u_0$  such that for any  $t > t_0$  and  $u > u_0$  it holds*

$$MV\left(\Gamma(a, b(t), N(t, u))\right) \approx MV\left(\Gamma(a, b(t_0), N(t_0, u_0))\right).$$

(By  $\approx$  we denote combinatorial equivalence relation for two complexes.)

**$t$ -stabilization:** for every  $u \geq 1$  there exists  $t_0$  such that for every  $t > t_0$  we have

$$MV\left(\Gamma(a, b(t), N(t, u))\right) \approx MV\left(\Gamma(a, b(t_0), N(t_0, u))\right).$$

**$u$ -stabilization:** for every  $t \geq 1$  there exists  $u_0$  such that for every  $u > u_0$  we have

$$MV\left(\Gamma(a, b(t), N(t, u))\right) \approx MV\left(\Gamma(a, b(t), N(t, u_0))\right).$$

*Remark 3.2.* Notice that the conditions that  $a$  and  $N$  are relatively prime, and that  $\alpha$  and  $\beta$  are relatively prime are equivalent to the fact that the corresponding rank-1 lattice  $L(a, b, N)$  satisfy Proposition 1.20.

In this section we give a proof of Minkowski–Voronoi complex stabilization Theorem. We do it in several steps. First we study the structure of the set of relative minima for the lattices of a fixed family in Subsection 3.1. Then in Subsection 3.2 we formulate a notion of asymptotic comparison of a pair of functions and prove the asymptotic comparison of the coordinate functions for the points of Minkowski–Voronoi complexes in the family. Finally, in Subsection 3.3 we conclude the proof of Theorem 3.1.

**Example 3.3.** Before to start the proof we study the following example. Consider the family of lattices  $\Gamma(a, b, N)$  with

$$a = 2, \quad b(t) = 14t + 2, \quad N(t, u) = 14tu + 7, \quad \text{where } u \geq 1 \text{ and } t \geq 0.$$

Then the corresponding Minkowski–Voronoi complexes are as follows.

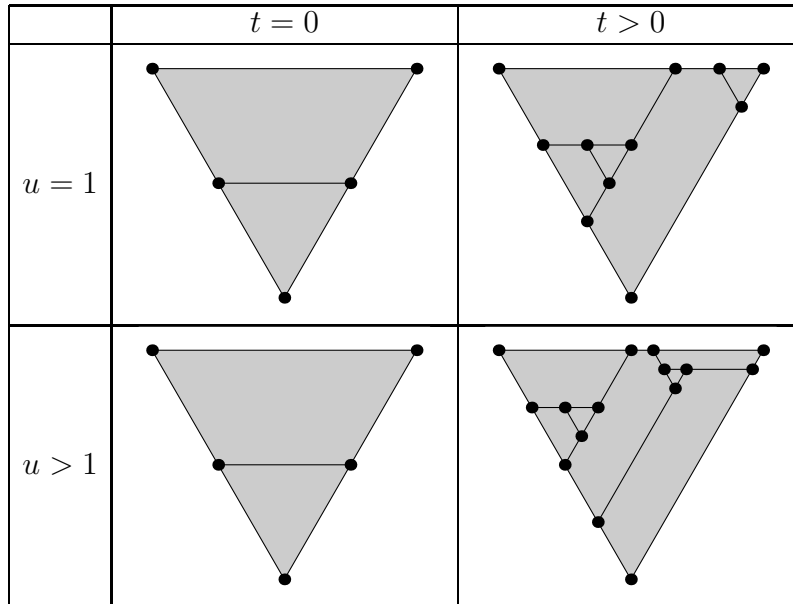

In this example we cover simultaneously two families described in the above theorem:

- 1).  $a = 2, \alpha = 7, \beta = 2, \gamma = 0$ ;
- 2).  $a = 2, \alpha = 7, \beta = 2, \gamma = 1$ .



In fact, it is quite common that for different values of  $\gamma$  the corresponding Minkowski–Voronoi complexes are almost the same, or even combinatorially coincide (like it is the case in this example).

**3.1. Classification of relative minima of  $\Gamma(a, b, N)$ .** In this section we show that all relative minima of  $\Gamma(a, b, N)$  fall into three categories of points, whose coordinates possess regularities which we further use in the proof of Theorem 3.1. The explicit description of these categories significantly reduces the construction time of the set of all relative minima for a given lattice.

**3.1.1. Some integer notation.** Let  $a$  and  $N$  be two numbers. Consider  $0 < b < N$  such that  $a - b$  is an integer divisible by  $N$ . We denote

$$b = a \bmod N.$$

Denote also

$$|a|_N = \min(a \bmod N, -a \bmod N).$$

**3.1.2. Three types of relative minima.** Consider the set  $\text{Vrm}(|\Gamma(a, b, N)|)$  of all Voronoi relative minima. Recall that each element of

$$\text{Vrm}(|\Gamma(a, b, N)|) \setminus \{(N, 0, 0), (0, N, 0), (0, 0, N)\}$$

is written in the form

$$(x, |ax|_N, |bx|_N)$$

for some integer  $x \in [1, \frac{N}{2}]$ . In what follows we distinguish relative minima of three types defined by the first coordinate  $x$ . First, let us decompose the interval  $I = [0, \frac{N}{2}]$  in the union

$$I = \bigcup_{k=0}^{a-1} I_k, \quad \text{where} \quad I_k = \left[ \frac{k}{2a}N, \frac{k+1}{2a}N \right).$$

Now every interval  $I_k$  we decompose into three more intervals:

$$I_k = I_{k,1} \cup I_{k,2} \cup I_{k,3},$$

where for even  $k$  we set

$$I_{k,1} = \left[ \frac{k}{2a}N, \frac{k}{2a}N + 1 \right), \quad I_{k,2} = \left[ \frac{k}{2a}N + 1, \frac{k}{2a}N + au + \gamma \right),$$

$$I_{k,3} = \left[ \frac{k}{2a}N + au + \gamma, \frac{k+1}{2a}N \right),$$

and for odd  $k$  we set

$$I_{k,1} = \left[ \frac{k+1}{2a}N - 1, \frac{k+1}{2a}N \right), \quad I_{k,2} = \left[ \frac{k+1}{2a}N - (au + \gamma), \frac{k+1}{2a}N - 1 \right),$$

$$I_{k,3} = \left[ \frac{k}{2a}N, \frac{k+1}{2a}N - (au + \gamma) \right).$$

We say that a relative minimum  $(x, |ax|_N, |bx|_N)$  is *of the first type*, *of the second type*, or *of the third type* if  $x \in I_{k,1}$ ,  $x \in I_{k,2}$ , or  $x \in I_{k,3}$  for some  $k$  respectively.

There are three more minima of  $\text{Vrm}(|\Gamma(a, b, N)|)$  except for the listed above, they are:  $(N, 0, 0)$ ,  $(0, N, 0)$ , and  $(0, 0, N)$ .

3.1.3. *Properties of relative minima of different types.* Let us describe some important properties of the set of relative minima with respect to their types.

**Proposition 3.4. Structural proposition.** (i) *Let  $(x, y, z)$  be a relative minimum of the first type of  $\text{Vrm}(|\Gamma(a, b, N)|)$ . Then there exists a nonnegative integer  $k \leq a - 1$  such that*

$$(1) \quad x = \begin{cases} \left\lfloor \frac{k}{2a} N \right\rfloor, & \text{if } k \text{ is even,} \\ \left\lfloor \frac{k+1}{2a} N \right\rfloor, & \text{otherwise.} \end{cases}$$

(ii) *Let  $(x, y, z)$  be a relative minimum of the second type. Then there exist a nonnegative even integer  $k \leq a - 1$  and  $\varepsilon \in \{0, 1\}$  such that  $x$  equals to one of the following numbers*

$$(2) \quad \left\lfloor N \left( \frac{k}{a} - \frac{1}{b} \left\{ \frac{k\beta}{a} \right\} \right) \right\rfloor + \varepsilon, \quad \left\lfloor N \left( \frac{k}{a} + \frac{1}{b} - \frac{1}{b} \left\{ \frac{k\beta}{a} \right\} \right) \right\rfloor + \varepsilon,$$

*or there exist a nonnegative odd integer  $k < a - 1$  and  $\varepsilon \in \{0, 1\}$  such that  $x$  equals to one of the following numbers*

$$(3) \quad \left\lfloor N \left( \frac{k+1}{a} - \frac{1}{b} \left\{ \frac{(k+1)\beta}{a} \right\} \right) \right\rfloor + \varepsilon, \quad \left\lfloor N \left( \frac{k+1}{a} + \frac{1}{b} - \frac{1}{b} \left\{ \frac{(k+1)\beta}{a} \right\} \right) \right\rfloor + \varepsilon,$$

(iii) *Let  $(x, y, z)$  be a relative minimum of the third type. Then it holds*

$$(4) \quad |bx|_N \leq \alpha.$$

*Proof.* We study two cases of odd and even  $k$  respectively.

**The case of even  $k$ .** Let us consequently consider three types of relative minima.

*Type 1.* The interval  $I_{k,1}$  is of unit length, and hence there is at most one local minimum with the first coordinate  $x \in I_{k,1}$ . If such a minimum exists then  $x$  satisfies (1).

*Type 2.* Let now  $x = \frac{k}{2a}N + x_1 \in I_{k,2}$ . Then

$$1 < x_1 < au + \gamma \quad \text{and} \quad a < |ax|_N = ax_1 < a(au + \gamma).$$

Suppose that  $(x, |ax|_N, |bx|_N)$  is a relative minimum. Then the point  $(1, a, b)$  should not be in the parallelepiped  $\Pi(x, |ax|_N, |bx|_N)$ , which is possible only if

$$(5) \quad |bx|_N \leq b.$$

From the definition of  $b$  we know that the period of the function  $f(x) = |bx|_N$  is exactly  $N/b > au + \gamma$ . Therefore the interval  $I_{k,2}$  contains at most two lattice points satisfying (5).

These points are the endpoints of a unit interval containing a root of  $f$ . The roots of  $f$  are the closest to the point  $\frac{k}{a}N$  are

$$N \left( \frac{k}{a} - \frac{1}{b} \left\{ \frac{k\beta}{a} \right\} \right), \quad N \left( \frac{k}{a} + \frac{1}{b} - \frac{1}{b} \left\{ \frac{k\beta}{a} \right\} \right),$$

lying at different sides from the point  $\frac{k}{a}N$ . (This follows from the equality  $\left\{ \frac{kb}{a} \right\} = \left\{ \frac{k\beta}{a} \right\}$ .) Hence the first coordinate of the point  $(x, |ax|_N, |bx|_N)$  of the second type should have one of the following values

$$\left\lfloor N \left( \frac{k}{a} - \frac{1}{b} \left\{ \frac{k\beta}{a} \right\} \right) \right\rfloor + \varepsilon, \quad \left\lfloor N \left( \frac{k}{a} + \frac{1}{b} - \frac{1}{b} \left\{ \frac{k\beta}{a} \right\} \right) \right\rfloor + \varepsilon, \quad \varepsilon = 0, 1.$$

This concludes the proof for the second type of relative minima that fall to the case of even  $k$ .

*Type 3.* Suppose now  $x = \frac{k}{2a}N + x_1 \in I_{k,3}$ . Then

$$au + \gamma < x_1 < \frac{N}{2a} \quad \text{and} \quad a(au + \gamma) < |ax|_N = ax_1 < \frac{N}{2}.$$

In case if  $(x, |ax|_N, |bx|_N)$  is a relative minimum, the parallelepiped  $\Pi((x, |ax|_N, |bx|_N))$  does not contain the point

$$(au + \gamma, |a(au + \gamma)|_N, |b(au + \gamma)|_N) = (au + \gamma, a(au + \gamma), \alpha),$$

which holds only if  $|bx|_N \leq \alpha$ .

**The case of odd  $k$ .** There exists at most one relative minimum with  $x \in I_{k,1}$ . In case of existence, the first coordinate of the minimum is

$$x = \left\lfloor \frac{k+1}{2a}N \right\rfloor.$$

Similarly to the case of even  $k$  the first coordinate of every relative minimum of the second types equals to one of the coordinates of (3), and the first coordinate of every relative minimum of the third type satisfies inequality (4). The proofs here literally repeat the proofs for the case of even  $k$ , so we omit them.  $\square$

3.1.4. *Definition of the list  $\Xi_N(a, b)$  and its basic properties.* Proposition 3.4 suggests the following definition.

**Definition 3.5.** For every  $a, b = b(t)$ , and  $N = N(t, u)$  we consider the lattice  $\Gamma(a, b, N)$ . Let us form a list  $\Xi_N(a, b)$  of all points mentioned in Proposition 3.4:

- First, we add to the list  $a$  points of the first type, mentioned in Proposition 3.4(i). We enumerate them with respect of  $k$ .
- Second, we consider  $4a$  points of the second type of Proposition 3.4(ii). We enumerate them with respect to  $k, \varepsilon$ , and the order in the strings (2) and (3) (i.e., for the same  $k$  and  $\varepsilon$  we choose the left one before the right one).
- Third, we count  $\alpha$  points of the third type mentioned in Proposition 3.4(iii). We choose the enumeration by the value of the last coordinate (i.e., by  $|bx|_N$ ).

- Finally, we add three points  $(N, 0, 0)$ ,  $(0, N, 0)$ , and  $(0, 0, N)$ .

*Remark.* Notice that some points in the list  $\Xi_N(a, b)$  could be counted several times, we do this with intension to use it further in the proof of Theorem 3.1.

From Proposition 3.4 we directly get the following corollary.

**Corollary 3.6.** (i) *Every relative minimum of  $|\Gamma(a, b, N)|$  is contained in the list  $\Xi_N(a, b)$ .*  
(ii) *The set  $\text{Vrm}(|\Gamma(a, b, N)|)$  contains at most  $\alpha + 5a + 3$  elements.*  $\square$

*Remark 3.7.* The statements of this corollary give rise to a fast algorithm constructing relative Minkowski-Voronoi complexes. Let us briefly outline the main stages of this algorithm.

*Stage 1:* construct  $\Xi_N(a, b)$ .

*Stage 2:* choose relative minima from the list  $\Xi_N(a, b)$ .

*Stage 3:* construct the diagram of the corresponding Minkowski-Voronoi complex.

Stages 1 and 2 are straightforward. Stage 3 is described above in Section 2. The numbers of additions and multiplications used by this algorithm do not depend on  $t$  and  $u$ .

The lists  $\Xi_N(a, b)$  considered as a family with parameters  $t$  and  $u$  have a remarkable property. First, they all have the same number of elements. Second, the elements with the same number in the lists form a two-dimensional families whose properties are described in the next proposition.

**Proposition 3.8.** *For fixed  $a, \alpha, \beta, \gamma$  consider a family of lists  $\Xi_N(a, b)$  with parameters  $(t, u)$ . Then for every  $s \leq \alpha + 5a + 3$  the  $s$ -th point in the lists  $\Xi_N(a, b)$  is written as  $p_s(t, u) = (|x|_N, |y|_N, |z|_N)$  where*

$$(6) \quad (x, y, z) = (A_1N + C_1u + D_1, A_2N + C_2u + D_2, A_3N + C_3t + D_3),$$

where the constants  $A_i, B_i, C_i, D_i$  depend on  $a, \alpha, \beta$ , and  $\gamma$ , and do not depend on  $t$  and  $u$ .

We start the proof with the following lemma.

**Lemma 3.9.** *Consider a family of point with coordinates  $(x(t, u), ax(t, u), bx(t, u))$ . Suppose that there exists an integer  $A$  and rational numbers  $C$  and  $D$  such that for every  $t$  and  $u$  the first coordinate of the family satisfies*

$$(7) \quad x(t, u) = \frac{A}{a}N + Cu + D, \text{ for some } A \in \mathbb{Z}.$$

Then the family satisfies condition (6).

*Proof.* The first coordinate satisfies condition (6) by definition. For the second and the third coordinates we have the following expressions:

$$y \equiv ax \equiv aCu + aD \pmod{N};$$

$$z \equiv bx \equiv \frac{A}{a}N\beta + C(N - \alpha) + Db(t) \pmod{N}.$$

Hence they also satisfy condition 6.  $\square$

Let us also recall the following definition.

**Definition 3.10.** *Continuants*  $K_s$  ( $s = 0, 1, \dots$ ) are the polynomials that are defined iteratively as follows:

$$\begin{aligned} K_0() &= 1, \\ K_1(x_1) &= x_1, \\ K_s(x_1, \dots, x_n) &= K_{n-1}(x_1, \dots, x_{n-1})x_n + K_{n-2}(x_1, \dots, x_{n-2}) \quad \text{for } n \geq 2. \end{aligned}$$

*Proof of Proposition 3.8.* Let us fix some admissible  $s_0$  and consider all the  $s_0$ -th entries in the lists  $\Xi_N(a, b)$ . We study the points of three different types separately.

*Points of the first type.* The first coordinates of the points of the first type are given by (1). Hence, equality (7) follows directly from the fact that  $N \equiv (\beta\gamma + \alpha) \pmod{a}$  and

$$\left\lfloor \frac{kN}{a} \right\rfloor = \frac{kN}{a} - \left\{ \frac{k(\beta\gamma + \alpha)}{a} \right\}.$$

Hence by Lemma 3.9 the points of the first type satisfy condition (6).

*Points of the second type.* Consider now the points of the second type with even  $k$  described by (2) (the case of odd  $k$  is similar). Notice that  $\varepsilon$  contributes only to the constant  $D$ , so it is sufficient to study the case  $\varepsilon = 0$ . Since

$$N \equiv \beta\gamma + \alpha \pmod{a} \quad \text{and} \quad \left\{ \frac{k\beta}{a} \right\} au \in \mathbb{Z},$$

we have

$$\begin{aligned} \left\lfloor \frac{kN}{a} - \frac{N}{b} \left\{ \frac{k\beta}{a} \right\} \right\rfloor &= k \frac{N - \beta\gamma - \alpha}{a} - \left\{ \frac{k\beta}{a} \right\} au + \left\lfloor \frac{c(k)}{a} - \left\{ \frac{k\beta}{a} \right\} \frac{\alpha}{b(t)} \right\rfloor \\ &= k \frac{N - \beta\gamma - \alpha}{a} - \left\{ \frac{k\beta}{a} \right\} au + \left\lfloor \frac{c(k) - 1}{a} \right\rfloor, \end{aligned}$$

where  $c(k) = (\beta\gamma + \alpha)k - a\gamma \left\{ \frac{k\beta}{a} \right\}$  is an integer. The last equality follows from the estimate  $\frac{\alpha}{b(t)} < \frac{1}{a}$  for all  $t \geq 1$ .

So the first coordinates of the points of the second type satisfy equality (7). Hence by Lemma 3.9 the points of the first type satisfy the condition (6).

*Points of the third type.* Every point of the third type has the coordinates

$$(b'k, ab'k, k) \quad \text{for } k \in \{1, 2, \dots, \alpha\},$$

where  $b'$  satisfies  $|bb'|_N = 1$ .

Let us find  $b'$  explicitly. Consider the regular continued fractions expansion

$$\frac{N}{b} = [a_0, \dots, a_s].$$

From the definition of  $N$  and  $b$  it follows that

$$a_0 = au + \gamma, \quad a_1 = at + \left\lfloor \frac{\beta}{\alpha} \right\rfloor, \quad \frac{\beta}{\alpha} - \left\lfloor \frac{\beta}{\alpha} \right\rfloor = [0, a_2, \dots, a_s].$$

Recall that

$$\begin{pmatrix} K_{s-1}(a_1, \dots, a_{s-1}) & K_s(a_1, \dots, a_s) \\ K_s(a_0, \dots, a_{s-1}) & K_{s+1}(a_0, \dots, a_s) \end{pmatrix} = \begin{pmatrix} K_{s-1}(a_1, \dots, a_{s-1}) & b \\ K_s(a_0, \dots, a_{s-1}) & N \end{pmatrix}$$

(here by  $K_m$  we denote the corresponding continuant of degree  $m$ ). From general theory of continuants it follows that the determinant of the above matrix is  $(-1)^s$ , we have that

$$|bK_s(a_0, \dots, a_{s-1})|_N = 1.$$

Hence, without loss of generality we set

$$b' = K_s(a_0, \dots, a_{s-1}).$$

Finally, let us examine the obtained expression for  $b'$ :

$$\begin{aligned} b' &= K_s(a_0, \dots, a_{s-1}) = a_0 K_{s-1}(a_1, \dots, a_{s-1}) + K_{s-2}(a_2, \dots, a_{s-1}) \\ &= (au + \gamma)(\zeta_1 t + \zeta_2) + \zeta_3 = \nu_1 N + \nu_2 u + \nu_3. \end{aligned}$$

where  $\xi_i$  and  $\nu_i$  ( $i = 1, 2, 3$ ) are constants. Therefore, the first and the second coordinates of the points of the third type, which are equal to  $kb'$  and  $akb'$  respectively, satisfy the conditions of the proposition. Finally, the third coordinates are constants  $k$  ( $k = 1, \dots, \alpha$ ), and they satisfy the conditions as well. Therefore, the points of the third type satisfy the conditions of the proposition. This concludes the proof.  $\square$

**3.2. Asymptotic comparison of coordinate functions.** In this section we formulate a notion of asymptotic comparison and prove two general statements that we will further use in the proof of Theorem 3.3.

**Definition 3.11.** We say that a function  $L : \mathbb{Z}_+^2 \rightarrow \mathbb{R}$  is *asymptotically stable* if there exist numbers  $\hat{t}$  and  $\hat{u}$ , such that the following conditions hold:

- *(t, u)-stability condition:* for every  $t \geq \hat{t}$ ,  $u \geq \hat{u}$  it holds  $L(t, u) = L(\hat{t}, \hat{u})$ ;
- *u-stability condition:* for every  $t_0 < \hat{t}$  and every  $u \geq \hat{u}$  it holds  $L(t_0, u) = L(t_0, \hat{u})$ ;
- *t-stability condition:* for every  $u_0 < \hat{u}$  and every  $t \geq \hat{t}$  it holds  $L(t, u_0) = L(\hat{t}, u_0)$ .

**Definition 3.12.** Two functions  $F_1$  and  $F_2$  are called *asymptotically comparable* if the function  $\text{sign}(F_1 - F_2)$  is asymptotically stable.

Let us continue with the following general statement.

**Proposition 3.13.** *Let  $A, B, D$  be arbitrary integer numbers. Set*

$$F(u, t) = AN + Bt + D.$$

*Then the following statements hold.*

(i) *There exist real numbers  $A', B', D'$ , and  $\hat{u}$  such that for every  $t \geq 1$  and  $u > \hat{u}$  we have*

$$|F(u, t)|_N = A'N + B't + D'.$$

(ii) For every  $u_0 \geq 1$  there exist real numbers  $B''$ ,  $D''$ , and  $\hat{t}$  such that for every  $t > \hat{t}$  we have

$$|F(u, t)|_N = B''t + D''.$$

*Remark 3.14.* It is clear that similar statements hold for the functions of type

$$F(u, t) = AN + Cu + D$$

(one should swap  $t$  and  $u$  in the conditions). The proof in these settings repeats the proof of Proposition 3.13, so we omit it.

*Proof of Proposition 3.13 (i).* First if  $|A| < 1/2$ , then there exists  $\hat{u}$  such that for every  $u > \hat{u}$  we have  $|F(t, u)| < N/2$ . Therefore, for every  $u > \hat{u}$  we get

$$|F(t, u)|_N = F(t, u).$$

Secondly, let  $A = 1/2$ . If  $B < 0$  or  $B = 0$  and  $D \leq 0$  then there exists  $\hat{u}$  such that for every  $u > \hat{u}$  we have  $0 < F(t, u) \leq N/2$  and hence

$$|F(t, u)|_N = F(t, u).$$

If  $B > 0$  or  $B = 0$  and  $D \geq 0$  then there exists  $\hat{u}$  such that for every  $u > \hat{u}$  we have  $N/2 \leq F(t, u) \leq N$  and hence

$$|F(t, u)|_N = N - F(t, u).$$

Finally, the cases when  $A \leq -1/2$  or  $A > 1/2$  are reduced to the above two cases by adding or subtracting the number  $N$  several times. Then the statement follows directly from the fact that  $|F(t, u) \pm N|_N = |F(t, u)|_N$ .  $\square$

*Proof of Proposition 3.13 (ii).* Let us fix  $u_0 \geq 1$ . In this case we consider the function  $F$  as a function in one variable  $t$ . We write

$$F(t, u_0) = Pt + Q,$$

for some real numbers  $P$  and  $Q$ . Let also

$$N = N_1(u_0)t + N_2(u_0).$$

If  $|P| < N_1(u_0)/2$  then there exists  $\hat{t}$  such that for every  $t > \hat{t}$  we have

$$|F(t, u_0)|_N = F(t, u_0).$$

Consider now the case  $P = N_1(u_0)/2$ . If  $Q \leq N_2(u_0)/2$  then there exists  $\hat{t}$  such that for every  $t > \hat{t}$  we have  $0 < F(t, u_0) \leq N/2$  and hence

$$|F(t, u_0)|_N = F(t, u_0).$$

If  $Q > N_2(u_0)/2$  then there exists  $\hat{t}$  such that for every  $t > \hat{t}$  we have  $N/2 < F(t, u_0) \leq N$  and hence

$$|F(t, u_0)|_N = N - Pt - Q.$$

Finally, the cases  $P \leq -N_1(u_0)/2$  or  $P > -N_1(u_0)/2$  are reduced to the above cases by adding or subtracting the number  $N$  several times. Then the statement follows directly from the fact that  $|F(t, u_0) \pm N|_N = |F(t, u_0)|_N$ .  $\square$

In order to compare the coordinates of the points in the lists  $\Xi_N(a, b)$  we formulate and prove the following statement.

**Proposition 3.15.** *Let  $F_1$  and  $F_2$  be a pair of functions of two variables as in one of the following cases:*

$$(i) \quad F_1(t, u) = A_1N + B_1t + D_1, \quad F_2(t, u) = A_2N + B_2t + D_2;$$

$$(ii) \quad F_1(t, u) = A_1N + C_1u + D_1, \quad F_2(t, u) = A_2N + C_2u + D_2.$$

*Then the functions  $|F_1|_N$  and  $|F_2|_N$  are asymptotically comparable.*

Without loss of generality we restrict ourselves to the first item (the proof for the second item repeats the proof for the first one). We start the proof with the following lemma.

**Lemma 3.16.** *The functions  $F_1$  and  $F_2$  are asymptotically comparable.*

*Proof.* By the definition it is sufficient to show that the function  $F = F_1 - F_2$  is comparable with a zero function. So let

$$F(t, u) = AN + Bt + D.$$

If  $A = 0$  then for  $t > -D/B$  the function  $F$  does not change its sign, for  $t < -D/B$  the function  $F$  does not change sign, and for any  $u$  we have  $F(-D/B, u) = 0$ . Hence  $F$  is asymptotically comparable with the zero function.

If  $A \neq 0$  then the equation  $F(t, u) = 0$  defines a hyperbola on  $(t, u)$ -plane, whose asymptotes are parallel to coordinate axes. Hence we have the asymptotic comparison of  $F$  and the zero function directly from definition (notice that we essentially use the fact that the function is defined over  $\mathbb{Z}_+^2$ ).  $\square$

*Proof of Proposition 3.15. Verification of  $(t, u)$ -stability and  $u$ -stability.* We show  $(t, u)$ -stability and  $u$ -stability condition of the function  $\text{sign}(|F_1|_N - |F_2|_N)$  simultaneously. By Proposition 3.13 (i) we know that there exists  $\widehat{u}_0$  such that for every  $t \geq 1$  and  $u > \widehat{u}_0$  both functions  $|F_1|_N$  and  $|F_2|_N$  are written as

$$|F_1(u, t)|_N = A'_1N + B'_1t + D'_1 \quad \text{and} \quad |F_2(u, t)|_N = A'_2N + B'_2t + D'_2.$$

By Lemma 3.16, such functions are asymptotically comparable. Hence there exist some constants  $\widehat{u}_1$  and  $\widehat{t}_1$  satisfying simultaneously  $(t, u)$ -stability and  $u$ -stability condition.

*Verification of  $t$ -stability.* Similarly from Proposition 3.13 (ii) follows the existence of the constant  $\widehat{t}_2$  satisfying  $t$ -stability condition for every  $u_0 < \widehat{u}_1$ .

Finally, the constants  $\widehat{t} = \max(\widehat{t}_1, \widehat{t}_2)$  and  $\widehat{u} = \widehat{u}_1$  satisfy all three stability conditions. Therefore,  $F_1$  and  $F_2$  are asymptotically stable. This concludes the proof of Proposition 3.15 (i).

As we have already mentioned the proof of Proposition 3.15 (ii) is similar and we omit it.  $\square$



**3.3. Conclusion of the proof of Theorem 3.1.** First of all we fix the constants:  $a, \alpha, \beta, \gamma$ . By Corollary 3.6(i) every relative minimum of  $|\Gamma(a, b, N)|$  is contained in the list  $\Xi_N(a, b)$ . Further by Proposition 3.8 for every admissible  $s$  the  $s$ -th entries  $p_s(t, u)$  in the lists  $\Xi_N(a, b)$  are written as

$$p_s(t, u) = (|A_1N + C_1u + D_1|_N, |A_2N + C_2u + D_2|_N, |A_3N + C_3t + D_3|_N), \quad t \geq 1, u \geq 1.$$

Hence by Proposition 3.15 for every admissible  $s_1$  and  $s_2$  each coordinate of  $p_{s_1}(t, u)$  is asymptotically comparable (with respect to  $t$  and  $u$ ) with the corresponding coordinate of  $p_{s_2}(t, u)$ . In other words, starting from some positive integers we have  $(t, u)$ -,  $t$ -, and  $u$ -stabilizations of all inequalities for all the coordinates for all the corresponding pairs of points in the lists (it is important that the number of points in every list is exactly  $\alpha + 5a + 3$ ). Recall that every Minkowski-Voronoi complex is defined completely by the inequalities between the same coordinates of different points. Therefore, the family of Minkowski-Voronoi complexes  $MV(\Gamma(2, b(t), N(t, u)))$  is  $(t, u)$ -,  $t$ -,  $u$ -stable.  $\square$

4. A FEW WORDS ABOUT LATTICES  $L(a, b, N)$  WITH SMALL  $a$

**4.1. Alphabetical description of canonical diagrams for lattices  $\Gamma(a, b, N)$  with small  $a$ .** In this subsection we say a few words about lattices with small parameter  $a$ . It turns out that canonical diagrams of such lattices are rather simple, there is a good way to describe their combinatorics. In order to do this we cut a diagram along the parallel lines in the horizontal direction, as it is shown in the example below.

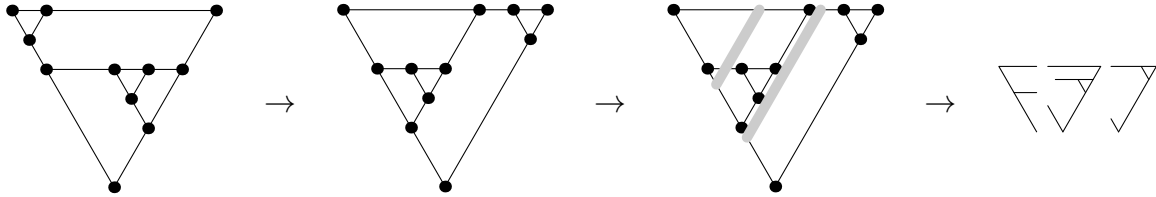

In this example

- first, we consider a canonical diagram for some  $S$  (the first picture from the left);
- then we rotate it by  $\frac{\pi}{3}$  clockwise (the second picture from the left);
- further we cut it in several parts by parallel cuts (the third picture from the left);
- finally, we redraw it in the symbolic form (the last picture from the left).

In some sense each diagram is written as a word in special letters, encoding the combinatorics of the obtained pieces after performing cuts. We choose the letters in the word to be similar to the corresponding parts (after the rotation by the angle  $\frac{\pi}{3}$ ).

Let us discuss diagram decompositions in the simplest case of  $a = 1, 2$ .

**4.2. The case of lattices  $\Gamma(1, b, N)$ .** We start with the case  $a = 1$ . It turns out that in this case every canonical diagram is represented by a word consisting of two letters “ $\nabla$ ” and “ $\nabla$ ”.

**Theorem 4.1.** *Let  $b$  and  $N$  be relatively prime positive integers, such that  $b \leq \frac{N}{2}$ . Then the canonical diagram of the set  $|L(1, b, N)|$  is defined by the following word:*

$$\searrow \nearrow \searrow \dots \nearrow,$$

where the number of letter “ $\nearrow$ ” equals to the number of elements in the shortest regular continued fractions of  $\frac{N}{b}$ .

*Remark 4.2.* The lattices of Theorem 4.1 have a remarkable property. They enumerate all lattice tetrahedra whose interiors do not contain lattice points. This classification was considered for the first time by G.K. White in [32].

*Proof.* The proof is based on all Voronoi relative minima enumeration.

Consider an ordinary continued fraction for  $b/N$ :

$$\frac{b}{N} = [0; a_1, \dots, a_s] \quad (a_1 \geq 2, a_s \geq 2).$$

Then, as it is shown by G.F. Voronoi [30, 31] all relative minima of the two-dimensional lattice generated by the vectors  $(N, 0)$  and  $(1, b)$  (we denote this lattice by  $\Gamma(b, N)$ ) are of the form

$$\gamma_j = (x_j, y_j) = ((-1)^{j+1} K_{j-1}(a_1, \dots, a_{j-1}), K_{s-j}(a_{j+1}, \dots, a_s)) \quad (0 \leq j \leq s+1),$$

In particular, we have  $\gamma_0 = (0, N)$ ,  $\gamma_1 = (1, b)$ ,  $\gamma_{s+1} = (\pm N, 0)$ .

Set

$$\tilde{\gamma}_j = (|x_j|, |x_j|, |y_j|), \quad \text{where } \gamma_j = (x_j, y_j).$$

Recall that the lattice  $L(1, b, N)$  is generated by  $(1, 1, b)$ ,  $(0, N, 0)$ , and  $(0, 0, N)$ . Notice that the set of Voronoi relative minima  $\text{Vrm}(|L(1, b, N)|)$  contains both  $(0, N, 0)$  and  $(0, 0, N)$ . All the other Voronoi relative minima are the points of type

$$(k \bmod N, k \bmod N, kb \bmod N) \in [0, N] \times [0, N] \times [0, N].$$

The first two coordinates of such points coincide with each other. Therefore, it is a local minimum in  $\Gamma(1, 1, b)$  if and only if the point  $(k \bmod N, kb \bmod N)$  is a local minimum in the lattice  $\Gamma(b, N) \subset \mathbb{Z}^2$ . Therefore, the set of all relative minima is as follows:

$$\{\gamma_x, \gamma_y, \gamma_z, \tilde{\gamma}_1, \dots, \tilde{\gamma}_s\},$$

where  $\gamma_x = (N, 0, 0)$ ,  $\gamma_y = (0, N, 0)$ , and  $\gamma_z = (0, 0, N)$ . So the vertices of the Minkowski-Voronoi complex correspond to the following triples

$$(\gamma_z, \tilde{\gamma}_1, \gamma_x), (\gamma_z, \tilde{\gamma}_1, \gamma_y), (\tilde{\gamma}_1, \tilde{\gamma}_2, \gamma_x), (\tilde{\gamma}_1, \tilde{\gamma}_2, \gamma_y), \dots, (\tilde{\gamma}_{s-1}, \tilde{\gamma}_s, \gamma_x), (\tilde{\gamma}_{s-1}, \tilde{\gamma}_s, \gamma_y), (\tilde{\gamma}_s, \tilde{\gamma}_x, \gamma_y).$$

Direct calculations show that the corresponding diagrams are as stated in the theorem.  $\square$

4.3. **The case of lattices  $\Gamma(2, b, N)$ .** We conjecture that the alphabet for the case  $a = 2$  consists of 14 letters.

**Conjecture 3.** Let  $b$  and  $N$  be relatively prime positive integers, such that  $b \leq \frac{N}{2}$ . Then the canonical diagram of Minkowski-Voronoi complex for the lattice  $L(1, b, N)$  is defined by the words whose letters are contained in the following alphabet:

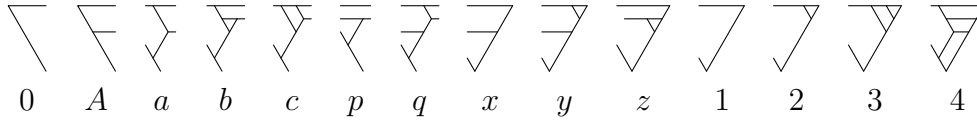

*Remark 4.3.* For simplicity we substitute the letters of this alphabet by the characters 0, A, a, b, c, p, q, x, y, z, 1–4 as above. Letters 0 and A always take the first position. The remaining part of the word splits in the blocks of two types. A *simple block* is a block with a simple number 0, 1, 2, 3, or 4. A *nonsimple block* starts with A, a, b, or c it can have several letters p and q in the middle and ends with x, y, or z. We separate such blocks with spaces. So in some sense a word in the original alphabet is a sentence in characters 0, A, a, b, c, p, q, x, y, z, 1–4.

*Remark 4.4.* The conjecture is checked for all lattices  $L(2, b, N)$  with  $b \leq 11$  and some other particular examples.

**Example 4.5.** Let us consider the lattice  $\Gamma(2, 26, 121)$ . The corresponding Minkowski-Voronoi complex has the following canonical diagram:

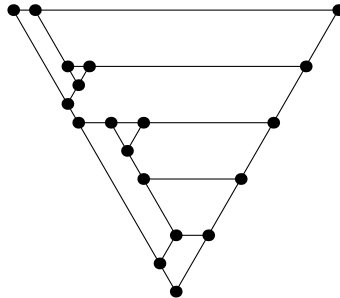

The corresponding word is  $\nabla \nabla \nabla \nabla \nabla \nabla$ , which is written in new characters as: 0 apz bx.

**Example 4.6.** Finally, let us list all stable configurations that are described in Minkowski-Voronoi complex stabilization theorem for  $a = 2$  and  $\alpha \leq 6$  (in the notation of Theorem 3.1).

$\alpha = 1$	$\beta = 1, \gamma = 0$	$u \geq 2, v \geq 2$	0 3 2
$\alpha = 2$	$\beta = 1, 3; \gamma = 1$	$u \geq 1, v \geq 1$	$Az$ 2
$\alpha = 3$	$\beta = 1; \gamma = 0$	$u \geq 2, v \geq 2$	0 2 3 2
	$\beta = 2; \gamma = 0, 1$	$u \geq 1, v \geq 1$	$Ax$ $bx$
	$\beta = 4; \gamma = 0, 1$	$u \geq 1, v \geq 1$	0 2 $bx$
	$\beta = 5; \gamma = 0$	$u \geq 2, v \geq 1$	$Ax$ 3 2
$\alpha = 4$	$\beta = 1, 5; \gamma = 1$	$u \geq 1, v \geq 1$	0 $bz$ 2
	$\beta = 3, 7; \gamma = 1$	$u \geq 1, v \geq 1$	0 $apz$ 2
$\alpha = 5$	$\beta = 1; \gamma = 0$	$u \geq 2, v \geq 2$	0 3 3 2
	$\beta = 2; \gamma = 0, 1$	$u \geq 1, v \geq 1$	$Az$ $bx$
	$\beta = 3; \gamma = 0$	$u \geq 2, v \geq 2$	$Apy$ 3 2
	$\beta = 4; \gamma = 0, 1$	$u \geq 1, v \geq 1$	0 4 $bx$
	$\beta = 6; \gamma = 0, 1$	$u \geq 1, v \geq 1$	0 3 $bx$
	$\beta = 7; \gamma = 0$	$u \geq 2, v \geq 1$	$Az$ 3 2
	$\beta = 8; \gamma = 0, 1$	$u \geq 1, v \geq 1$	$Apy$ $bx$
	$\beta = 9; \gamma = 0$	$u \geq 2, v \geq 1$	0 4 3 2
$\alpha = 6$	$\beta = 1, 7; \gamma = 1$	$u \geq 1, v \geq 1$	0 $bz$ 2
	$\beta = 5, 11; \gamma = 1$	$u \geq 1, v \geq 1$	0 $cpz$ 2

Experiments show that not all possible configurations of letters are realizable. One of the natural questions here is as follows.

**Problem 4.** (i) Find combinations of letters that are not realizable for  $\Gamma(2, b, N)$  lattices. (ii) Find combinations of letters that are not realizable for rank-1 integer lattices.

Finally we would like to raise the following general question for  $a > 2$ .

**Problem 5.** Let  $a > 2$  be an integer. Does there exist a finite alphabet describing all the diagrams for  $\Gamma(a, b, N)$ ?

In fact, we have some evidences of the existence of finite alphabets for  $a > 2$ , although the number of letters in them might be relatively large.

**Acknowledgement.** Some part of the work related to this paper was performed at TU Graz. Both authors are grateful to TU Graz for hospitality and excellent working conditions. Alexei Ustinov is supported by Dynasty Foundation and RFBR grant 14-01-90002.

## REFERENCES

- [1] M.O. Avdeeva, V.A. Bykovskii, *An analogue of Vahlen's theorem for simultaneous approximations of a pair of numbers*, Mat. Sb., 2003, 194, 3–14.
- [2] M.O. Avdeeva, V.A. Bykovskii, *Refinement of Vahlens Theorem for Minkowski Bases of Three-Dimensional Lattices*, Mathematical Notes, 2006, 79, 151-156.
- [3] J. Buchmann, *A generalization of Voronoï's unit algorithm. I*, J. Number Theory, 1985, 20, 177–191.
- [4] J. Buchmann, *A generalization of Voronoï's unit algorithm. II*, J. Number Theory, 1985, 20, 192–209.

- [5] J. Buchmann, *The computation of the fundamental unit of totally complex quartic orders*, Math. Comput., 1987, 48, 39–54.
- [6] J. Buchmann, *On the computation of units and class numbers by a generalization of Lagrange’s algorithm*, J. Number Theory, 1987, 26, 8–30.
- [7] V.A. Bykovskii, *Vahlen’s theorem for two-dimensional convergents of continued fractions*, Mat. Zametki, 1999, 66, 30–37.
- [8] V.A. Bykovskii, *Local Minima of Lattices and Vertices of Klein Polyhedra*, Funkts. Anal. Prilozh., 2006, 40:1, 69–71.
- [9] V. Bykovskii, *The discrepancy of the Korobov lattice points*, Izvestiya: Mathematics :3, 2012, 76, 446–465.
- [10] J.W.S. Cassels, *Swinerton-Dyer H. P. F. On the product of three homogeneous linear forms and the indefinite ternary quadratic forms*, Philos. Trans. Roy. Soc. London. Ser. A., 1955, 248, 73–96.
- [11] J.W.S. Cassels, *An introduction to the geometry of numbers*, Springer-Verlag, Berlin, 1997, viii+344.
- [12] T.W. Cusick, *Diophantine approximation of ternary linear forms*, Math. Comp., 1971, 25, 163–180.
- [13] T.W. Cusick, *The two-dimensional Diophantine approximation constant*, II Pacific J. Math., 1983, 105, 53–67.
- [14] H. Davenport, *On the product of three homogeneous linear forms*, IV Proc. Cambridge Philos. Soc., 1943, 39, 1–21.
- [15] B.N. Delone, D.K. Faddeev, *The theory of irrationalities of the third degree*, Providence, American Mathematical Society, 1964.
- [16] B.N. Delone, *The St. Petersburg school of number theory. History of Mathematics, 26*, American Mathematical Society, Providence, RI, 2005.
- [17] S. Felsner, F. Zickfeld, *Schnyder woods and orthogonal surfaces*, Discrete Comput. Geom., Springer-Verlag, New York, NY, 2008, 40, 103–126.
- [18] Ph. Furtwängler, M. Zeisel, *Zur Minkowskischen Parallelepipedapproximation*, Monatsh. f. Math., 1920, 30, 177–198.
- [19] O.N. German, *Klein polyhedra and relative minima of lattices*. Math. Notes, 2006, 79, 505–510.
- [20] H. Hancock, *Development of the Minkowski geometry of numbers*, Dover Publications Inc., 1964, vol. 1–2.
- [21] C. Hermite, *Letter to C.D.J. Jacobi*, J. Reine Angew. Math., 40:286, 1839.
- [22] O. Karpenkov, *Geometry of continued fractions*, Algorithms and Computation in Mathematics, 26, Springer-Verlag, Berlin, 2013, xvii+405.
- [23] H. Minkowski, *Generalisation de la theorie des fractions continues*, Ann. de l’Ecole Norm., 1896, 13, 41–60.
- [24] H. Minkowski, *Zur Theorie der Kettenbrüche*. In “Gesammelte Abhandlungen”. Leipzig: Druck und Verlag von B. G. Teubner, 1911, 1, 278–292.
- [25] P.M. Pepper, *Une application de la géométrie des nombres à une généralisation d’une fraction continue*. Annales scientifiques de l’É.N.S., 3 série, 1939, 56, 1–70.
- [26] G. Ramharter, *On Mordell’s inverse problem in dimension three*, J. Number Theory, 1996, 58, 388–415.
- [27] H.P.F. Swinnerton-Dyer, *On the product of three homogeneous linear forms*, Acta Arith., 1971, 18, 371–385.
- [28] A.V. Ustinov, *Minimal Vector Systems in 3-Dimensional Lattices and Analog of Vahlen’s Theorem for 3-Dimensional Minkowski’s Continued Fractions*, Mathematics and Informatics, 1, Dedicated to 75th Anniversary of Anatolii Alekseevich Karatsuba, Sovrem. Probl. Mat., 16, Steklov Math. Inst., RAS, Moscow, 2012, 103–128.
- [29] Ustinov A. V. *On the Three-Dimensional Vahlen Theorem*. Mat. Zametki, 95:1 (2014), 154–156.
- [30] G.F. Voronoi, *On a generalization of the algorithm of continued fractions*. PhD Dissertation, Warsaw, 1896.

- [31] G.F. Voronoi, *Collected Works* [in Russian], vol. 1, Kiev, 1952.
- [32] G.K. White, *Lattice tetrahedra*. *Canad. J. Math.*, 1964, 16, 389–396.
- [33] H. Williams, G. Cormack, E. Seah, *Calculation of the regulator of a pure cubic field*. *Math. Comput.*, American Mathematical Society, Providence, RI, 1980, 34, 567–611.
- [34] H. Williams, *Some results concerning Voronoi's continued fraction over  $Q(D^{1/3})$* . *Math. Comput.*, 1981, 36, 631-652.

*E-mail address*, Oleg Karpenkov: `karpenk@liv.ac.uk`

*E-mail address*, Alexey Ustinov: `ustinov@iam.khv.ru`